

Cavity HOMs as BPMs

(SLAC)

Josef Frisch, Kirsten Hacker, Linda Hendrickson, Justin May, Douglas McCormick,
Caoliann O'Connell, Marc Ross, Steve Smith, Tonee Smith

(DESY)

Gennady Kreps, Nicoleta Baboi, Manfred Wendt

(CEA/Saclay)

Olivier. Napoly and Rita. Paparella,



Higher Order Modes

- In addition to the fundamental accelerating mode, Superconducting cavities support additional higher frequency modes
 - Monopole modes: Sensitive to beam current
 - Dipole modes: Sensitive to beam current X Beam position offset
 - Higher multipoles: (not discussed further here).
- The superconducting accelerator cavities in the Tesla Test Facility, (and the proposed International Linear Collider) are equipped with couplers to damp higher order modes
 - Each cavity has 2 couplers, one at each end, at a relative angle of 115 degrees.
 - The signals from these couplers can provide information on the cavity shapes, and on the beam orbit through the cavity.
- Experimental run in November 2004 at the TTF to study HOM signals produced by single bunch beam.

Dipole Mode Response to Beam



Beam position offset produces mode amplitude proportional to position \times charge

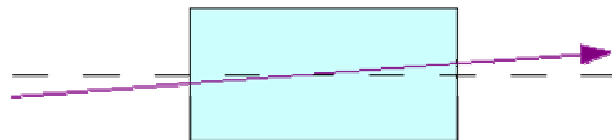

Beam at angle produces signal at start of structure, cancels at end of structure:
Result is “derivative” like signal, 90 degrees out of phase with position signal

Amplitude is proportional to Angle \times charge \times cavity length

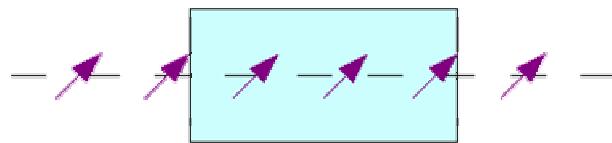

Bunch tilt signal produces a signal with the same phase as the beam angle signal

Amplitude is proportional to Tilt \times charge \times bunch length

Not significant for the DESY TTF
(bunches are very short)

TTF2 Layout

TTF2 operates at 1.3 GHz fundamental frequency
HOM signals studied from ~1.6-2.4 GHz

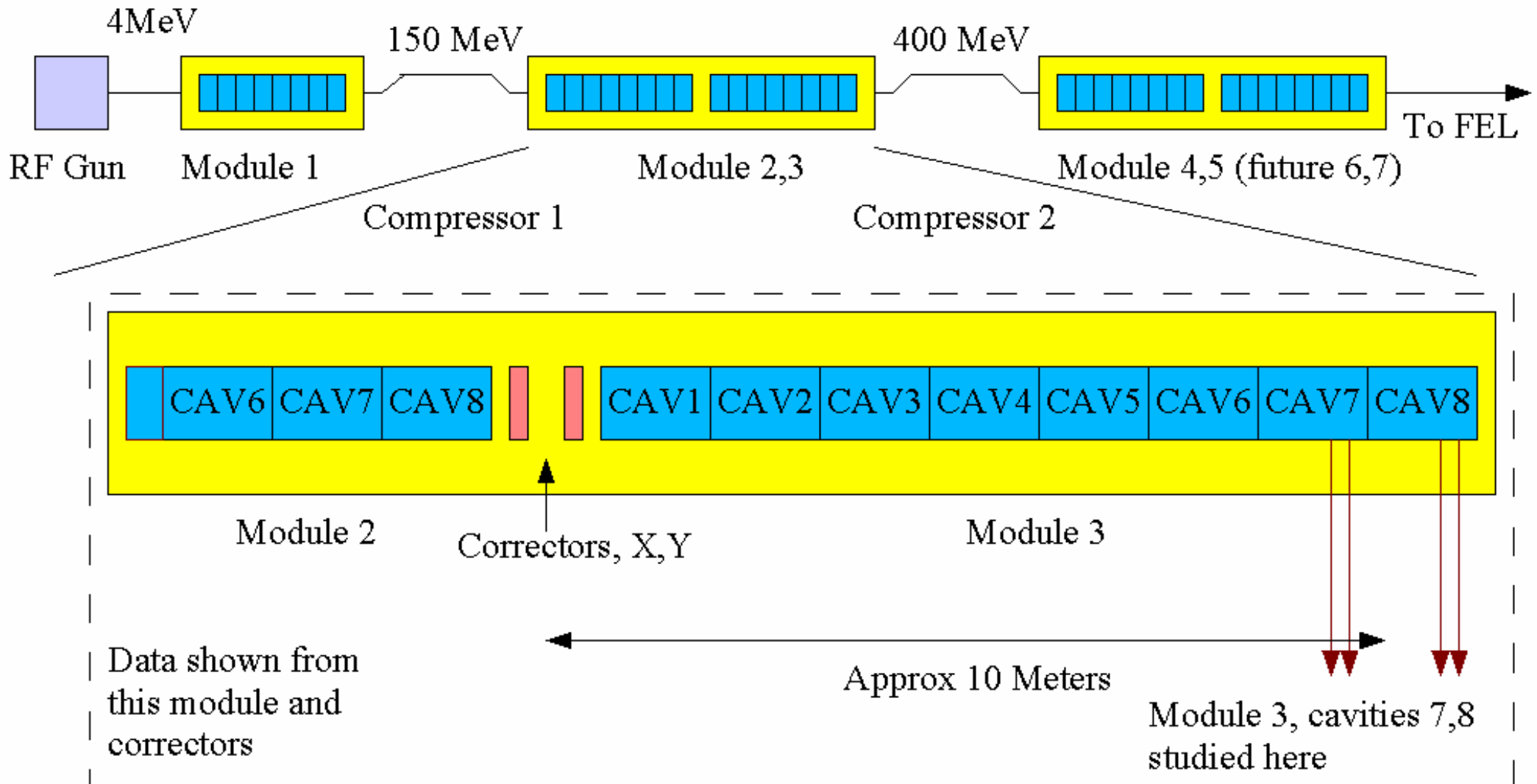

Experimental Run

Steer X,Y correctors in +1, 0, -1 Amp box pattern. (1 Amp ~ 1 mm at structures).

Note: only one plane steering available for this experiment. (no X',Y').

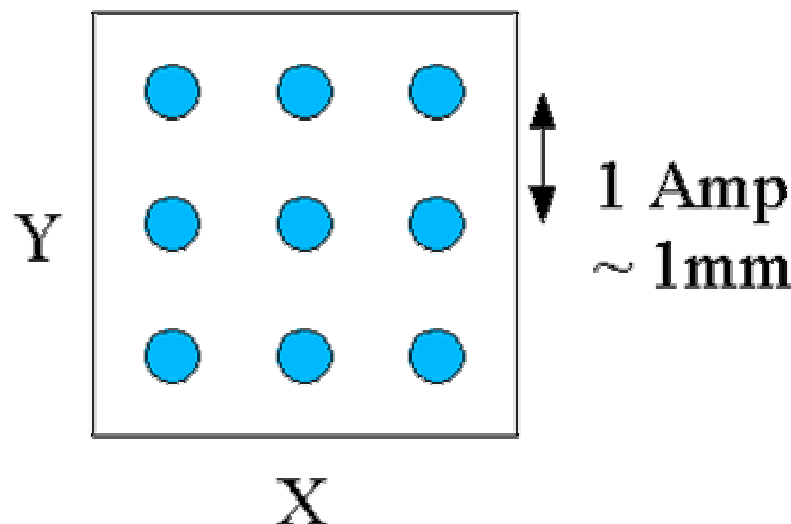

- Collect data for 10 beam pulses for each of the 9 steering settings.
- Repeat data sets for 0,0 position.
- Total of 109 good beam pulses.
- No independent TTF beam position or charge measurements – must extract all information from steering settings and HOM measurements.

Electronics Setup

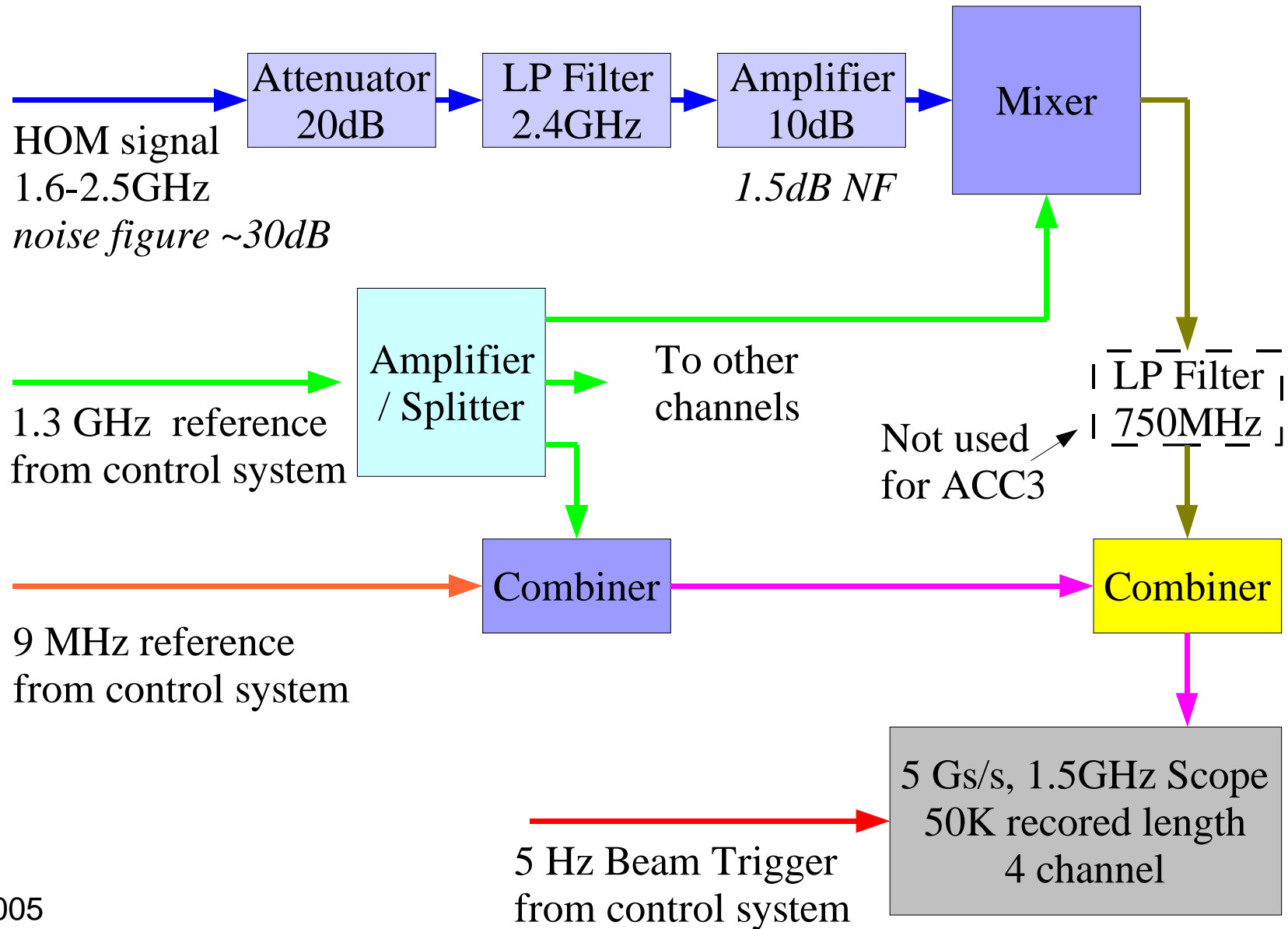

Electronics Operation

- The first 2 dipole bands from 1.6-1.9GHz are mixed with the 1.3GHz reference to 300-600MHz.
- The Monopole band near 2.4MHz is mixed to 1.1GHz
- Signal timing (for phase measurements) derived from TTF control system triggers, 9MHz reference and 1.3GHz reference
 - Control system problems necessitated the use of offline reconstruction of timing from the monopole modes
- Data was collected on 4 simultaneous oscilloscope channels each operating at 5Gs/s, approximately 8 bits.
- This was a “first attempt” data acquisition system – many parameters were not optimized.

Raw Signals

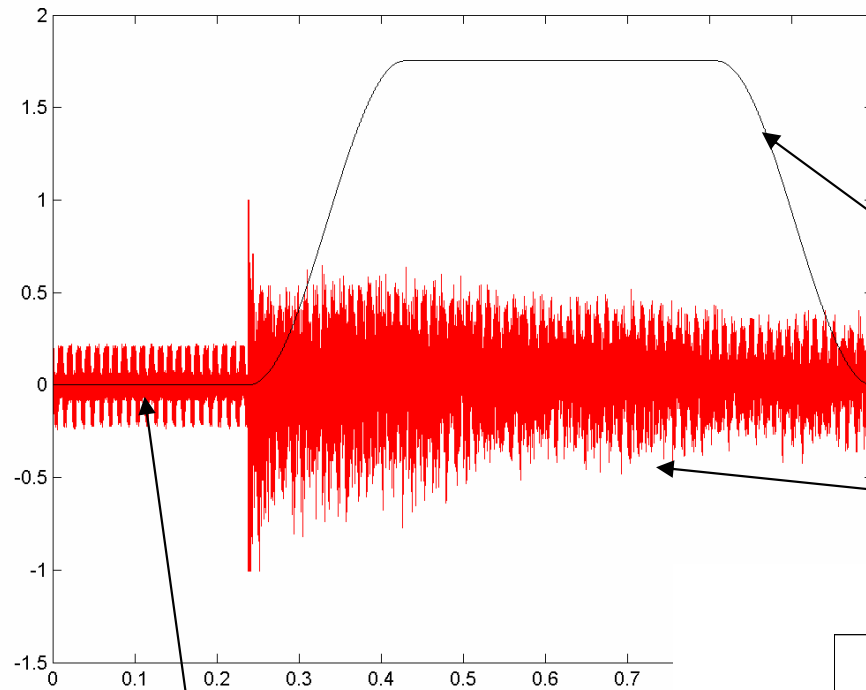

Window Function (offset "Tukey")

~ 10 microsecond decay of
HOM signals

Raw signal ACC3-7, coupler 1

1.3 GHz and 9MHz reference
signals

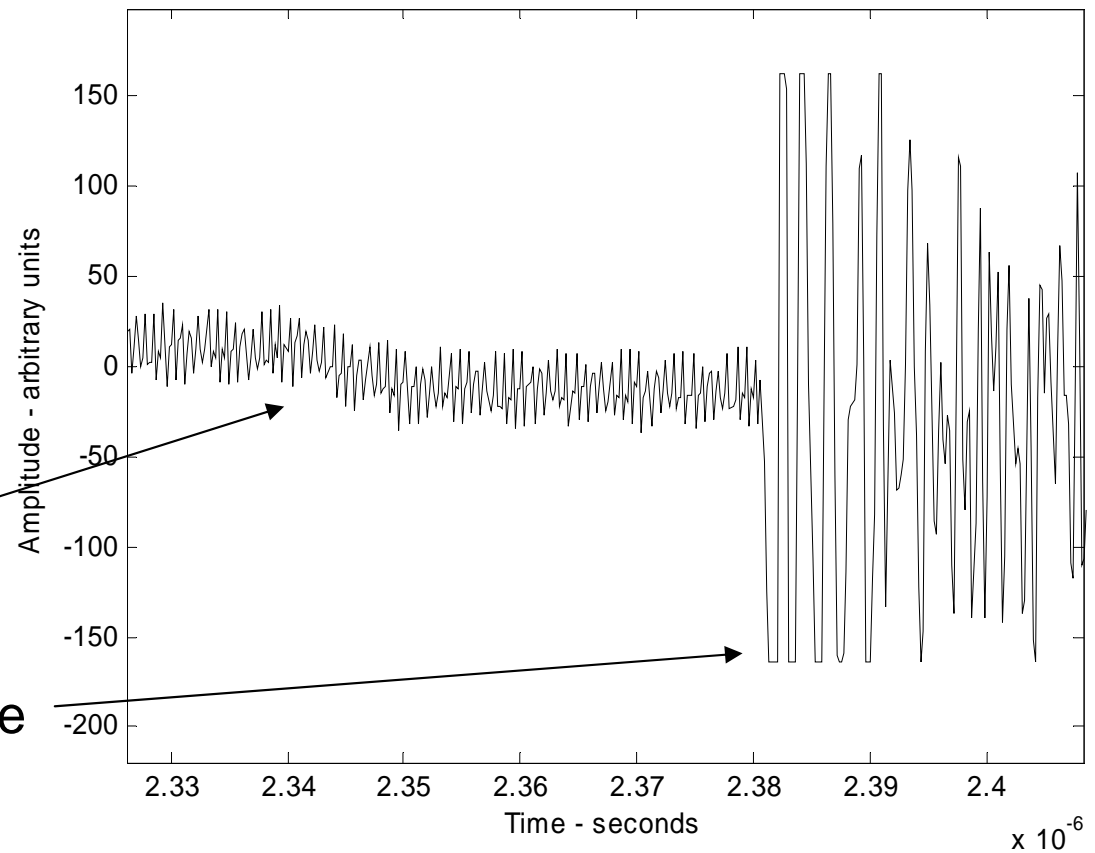

Main signal saturated near beam time
4/12/2005

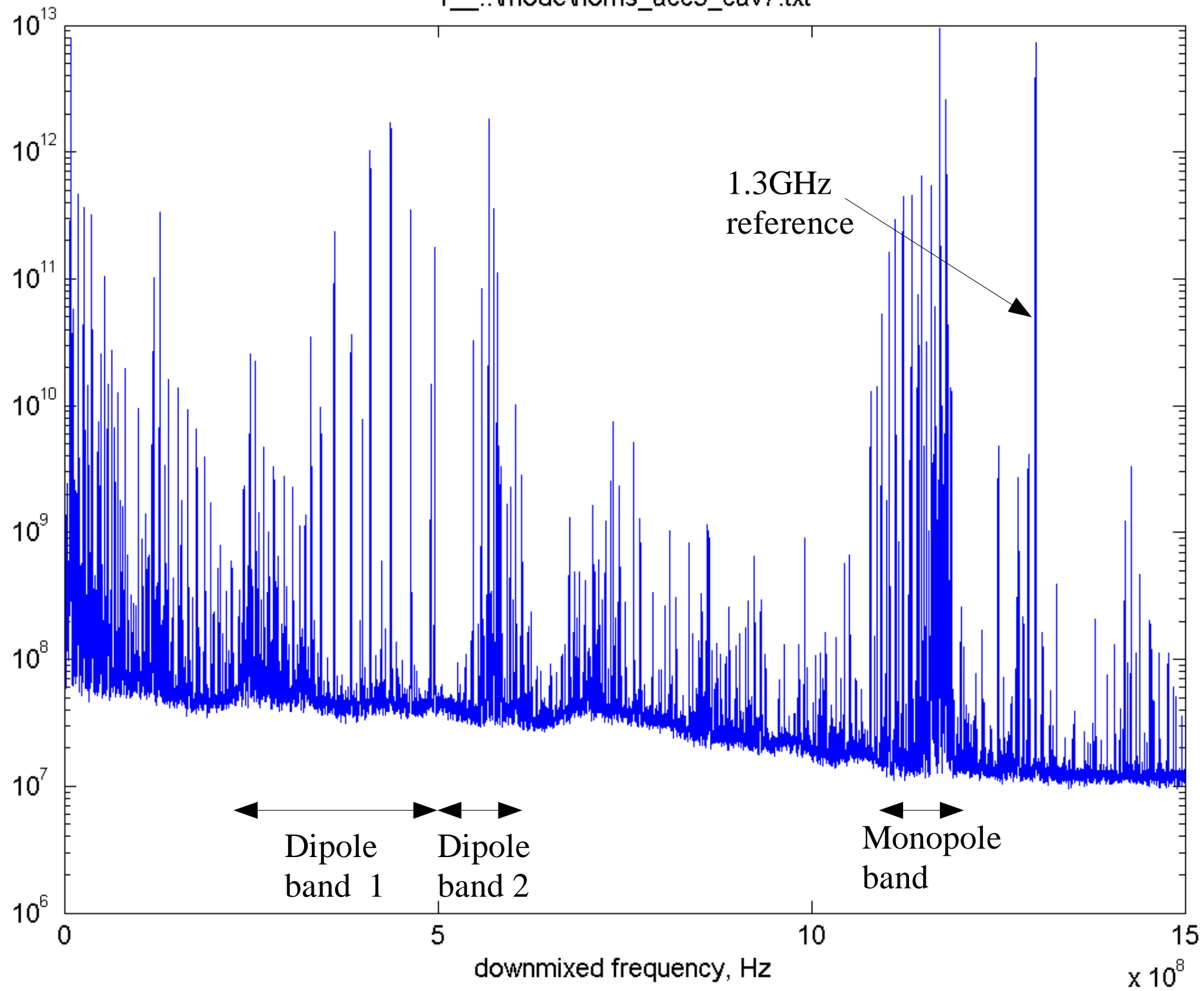

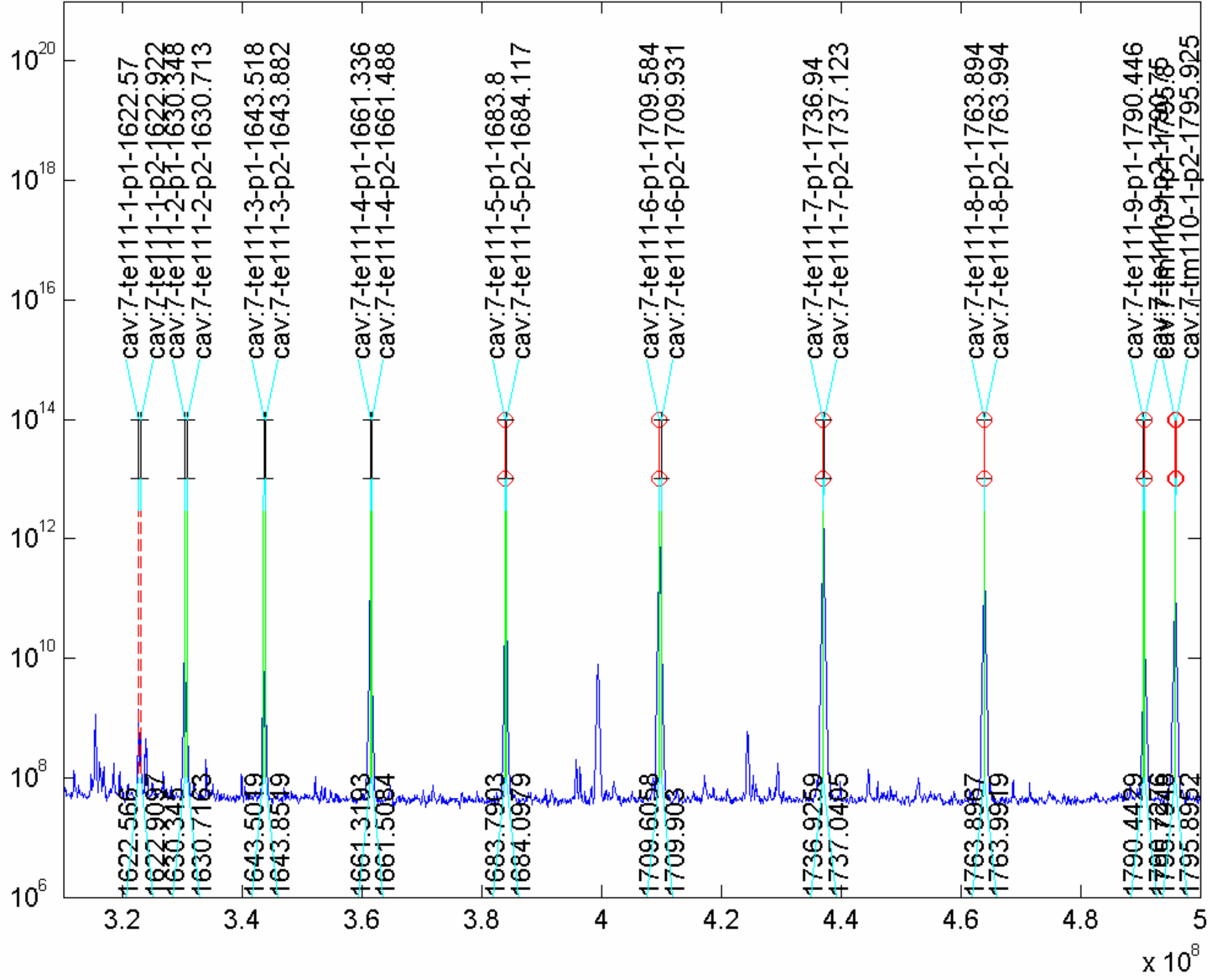

cav:7-te111-6-p1-1709.584

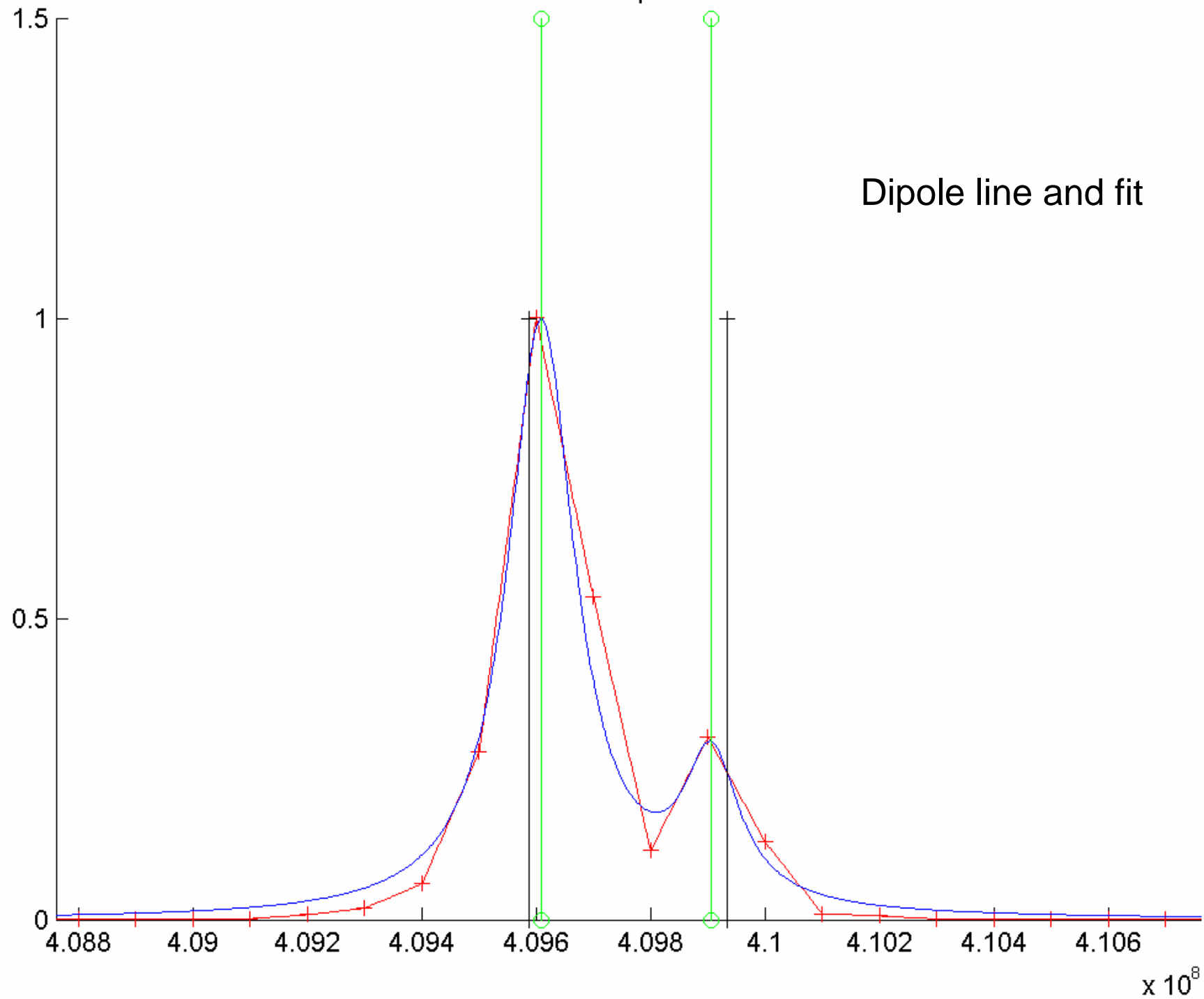

Timing / Phase Measurement

- Phase of dipole HOM signal provides information on the sign of the displacement (and on beam angle through the structure).
- In order to measure phase of signals with varying frequencies, need to have a time reference with an accuracy of a fraction of the beat frequency between the signals.
 - For a few X 100MHz -> need 10 picosecond measurement for ~ 1 degree accuracy.
- Timing system problems necessitated the use of monopole cavity signals to measure the beam arrival time.
 - Monopole signal timing sufficient to select a single cycle of the 1.3GHz reference signal.
 - Then, 1.3GHz phase used for precise timing determination
 - Believe system good to ~ few picoseconds.
 - Method somewhat complex – and not particularly interesting.
 - Offline only – so far.
- Need a good timing reference to allow online display of beam position

Select Dipole Modes for Analysis

- Near “speed of light” modes have strongest coupling: TE111-6,7, TM110-4,5
- For this analysis we use Cavity 7, TE111-6 as “reference” mode.
- Dipole modes have 2 orthogonal polarizations. For some modes, the separation is less than a line width, and the modes must be distinguished by the relative signals at the 2 couplers.
- Record (complex) dipole mode amplitude for each data set for each mode.
 - (real, imag) X (2 couplers) X (2 polarizations) = **8** real signals per mode.

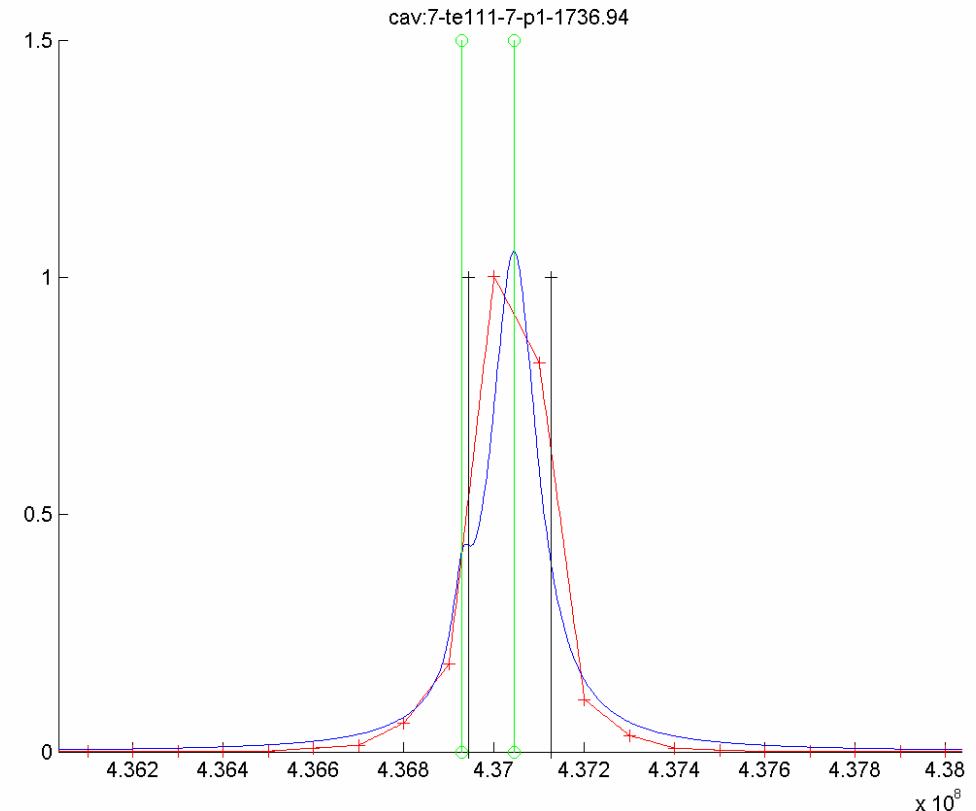

Linear Regression

(a brief digression)

- Given a set of measurements for a set of variables, predict the measurements for one variable based on the others.
- Prediction is a linear combination of the other variables for that measurement.
- Linear combination is chosen to minimize the RMS error of the prediction of the variable over all measurements.
- **Need more measurements than variables!!!**
- Can use regression to predict components of one mode from components of another mode.
- Can also use to predict X and Y, from mode components.

Set of Measurements $M_{a,b}$ on the “reference” mode where “a” is the data set (1:109 for our data), and “b” is one of the 8 components of the mode:

Polarization 1 or 2
 Coupler 1 or 2
 Real or Imaginary part

$$\begin{bmatrix} M_{1,1} & \dots & M_{1,8} \\ M_{2,1} & \dots & \dots \\ \dots & \dots & \dots \\ M_{109,1} & \dots & M_{109,8} \end{bmatrix} \begin{bmatrix} 1 \\ 1 \\ 1 \\ 1 \end{bmatrix} \begin{bmatrix} R_1 \\ \dots \\ R_9 \end{bmatrix} = \begin{bmatrix} M_{1,x} \\ M_{2,x} \\ \dots \\ M_{109,x} \end{bmatrix}$$

Set of measurements on the “target” or “predicted” mode $M_{a,x}$ where “a” is again the data set (1:109 for us) , x is a single component (out of 8) for the target mode.

Set of coefficients which best (in a “least squares” sense) predict the “target” mode component. R_b where “b” is one of the 8 mode components, AND the offset.

These coefficients R are found by “linear regression”, in our case the arithmetic is done by *Matlab*.

Predict Cav7:TE111-7 from components of Cav7:TE111-6

Signal measured in cavity 7, mode 7

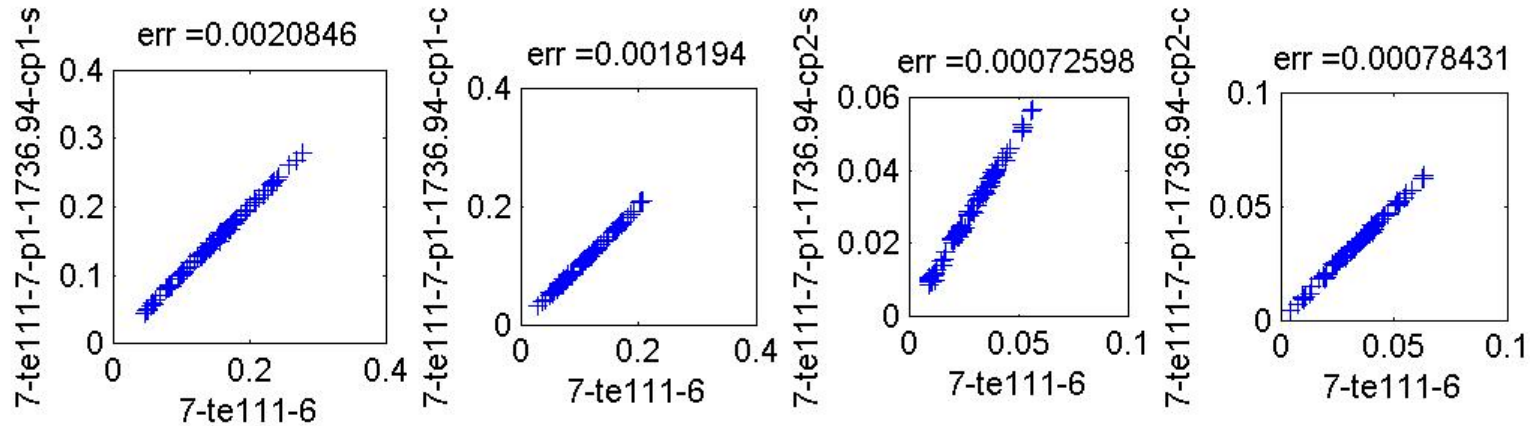

Total beam motion ~3 mm, gives signal of ~0.4 (arb units)
Fit error ~0.0015, corresponds to ~ 10 microns

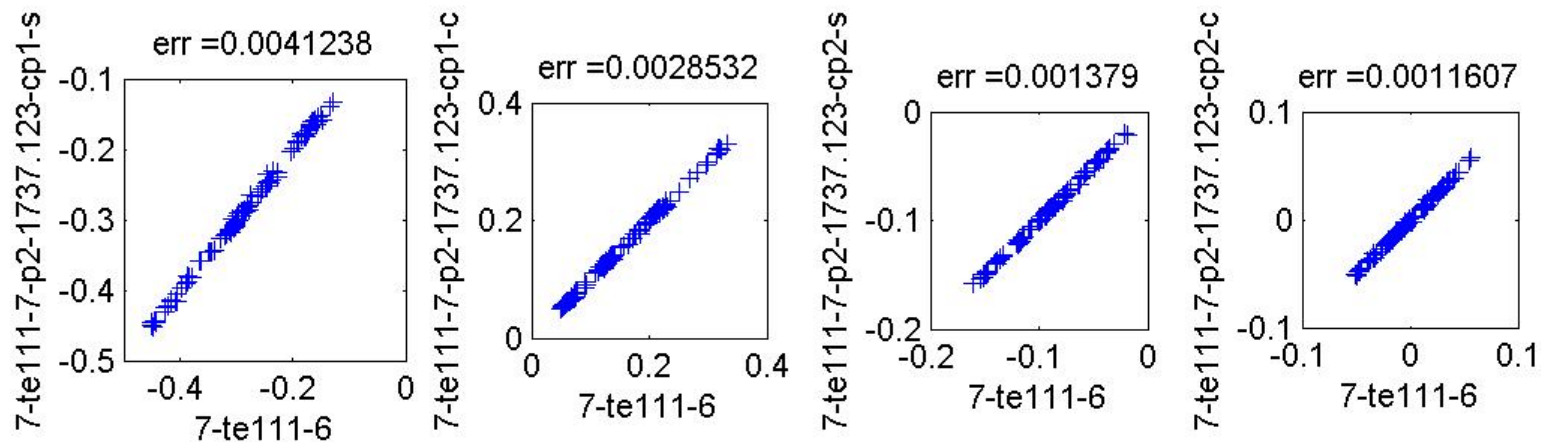

Using Dipole Modes to Measure Beam Position

- Take measured mode signals vs. corrector strengths
 - Use 8 components of a single mode
- Use linear regression to make best prediction of corrector settings (and corresponding positions) from measured mode signals
 - Note that we only measured steering at one beam phase (X and Y, not X' and Y').
 - 2 uncontrolled degrees of freedom – believed to be smaller than intentional motions.
 - Using 4 degrees of freedom for current tests.
 - Beam random jitter believed to be larger than noise of measurement from modes
- Unfortunately for this experiment had not independent measurement of beam position (Conventional BPM data was not available to the data acquisition system).

X vs Y from Cav 7, TE111-6

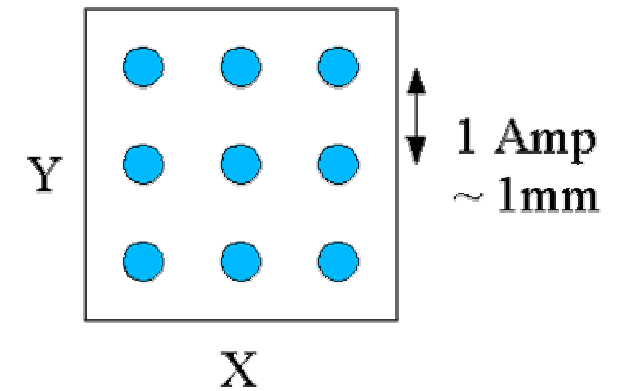
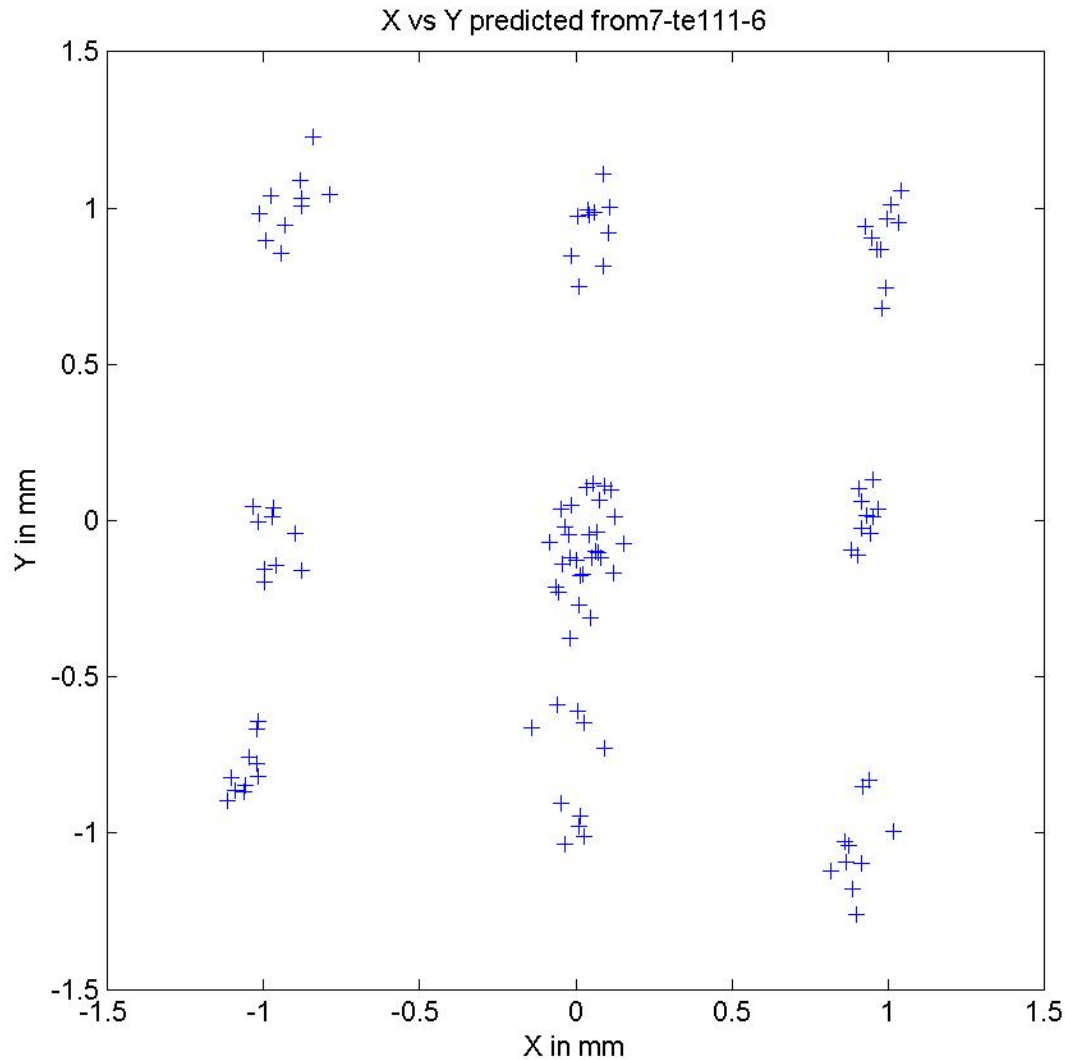

Note, X , Y believed swapped
In data:

Estimating BPM noise

- 2 methods to estimate noise (Here use the cavity 7, TE111-6 mode as “reference”, and the TE111-7 mode as “target”):
 - 1a. Use LR to predict X,Y from the target mode
 - 1b. Use LR to predict target mode from reference mode
 - 1c. Compare:
 - X,Y predicted from target mode
 - **TE111-7 Predicts X,Y**
 - X,Y predicted from mode predicted from **reference mode**
 - **TE111-6 predicts TE111-7, which predicts X,Y**
 - 1 *This method is independent of beam noise*
 - 2a. Use LR to predict X,Y from target mode
 - 2b. Use LR to predict X,Y from reference mode
 - 2c. Compare:
 - X,Y predicted from target mode
 - **TE111-7 predicts X,Y**
 - X,Y predicted from reference mode
 - **TE111-6 predicts X,Y**
 - 2 *This method is more straightforward, but is sensitive to beam noise*

Position Measurement Noise

X predicted by 2 modes, error =0.028974

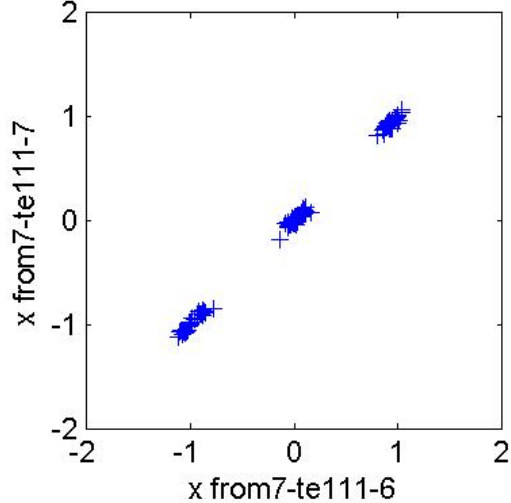

Y predicted by 2 modes, error =0.049928

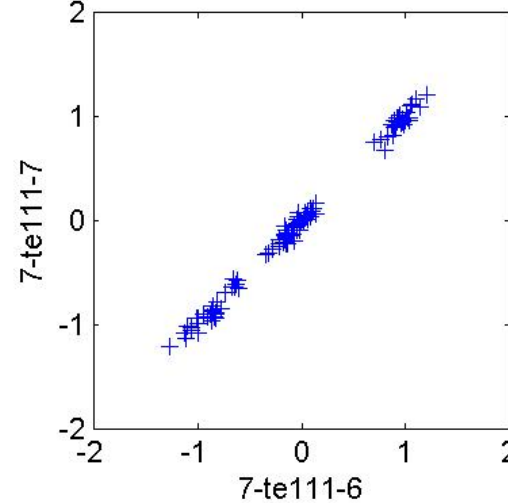

X alternate, error =0.030002

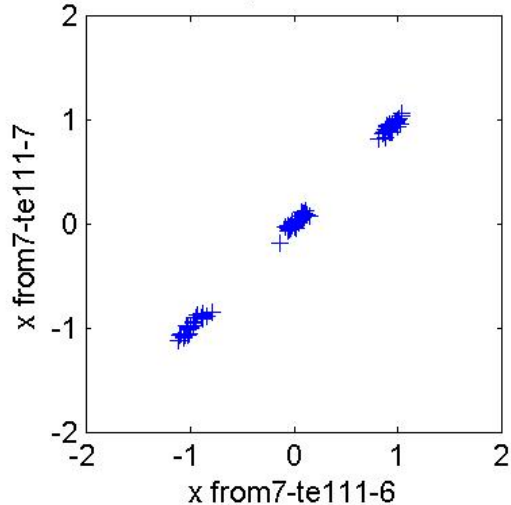

Y alternate, error =0.058953

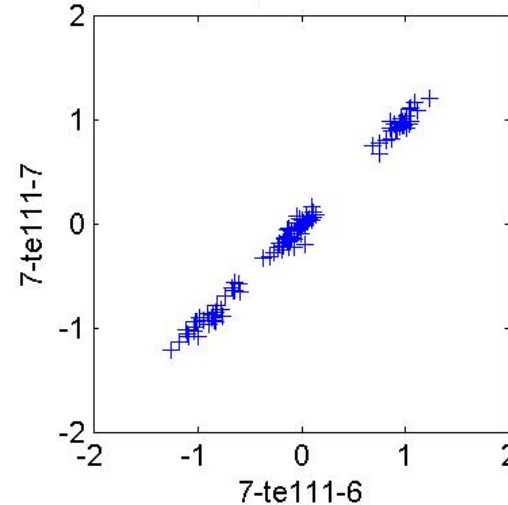

Error ~30 microns
Corresponds to ~20
microns noise for single
measurement

Noise Sources and Limits

- System performance ~20 microns resolution single mode.
- System noise figure ~30dB.
- For noise figure = 10dB system should have 2 micron resolution
 - 20dB attenuators at front end removed for current run.
- System uses 8 bit digitizer, 5Gs/s, 10 microsecond window, ~10 simultaneous modes: Corresponds to an amplitude dynamic range of ~20,000:1.
 - For 100 lines, ~2000/1 dynamic range / line, ~ 1 micron: not a limitation
 - Single line even better.
 - More conventional 12 Bit, 100Ms/s digitizers, used for single modes would give 130,000:1 dynamic range
 - Not expected to be a limitation.
- By converting to narrow band system, we expect ~ 2 micron resolution extrapolating from existing system.
 - Testing this now
- Mode impedance is ~10 Ohms/cm² which gives a theoretical resolution around 30 nanometers at 1 nanocoulomb (10dB noise figure room temperature amplifier)
 - Need to reconcile theoretical vs. measured noise. (X100)

HOM Cavity Diagnostics

- Can use the predicted (from regression) X,Y for zero amplitude HOM signals to find cavity “center”
 - Comparison between cavities provides a measurement of the alignment of the structure
 - Comparison between modes can be compared with theoretical mode position offsets to calculate cavity fabrication errors.
 - Appear to have <50 micron resolution with existing system, but interference with spurious lines in the spectrum may contaminate data.
 - Narrow band system should greatly reduce spurious lines.
- Can use measured mode angle, frequency splitting (between 2 polarizations) to estimate cavity errors.
 - Analysis complicated by partially degenerate mode frequencies

Current HOM experiment (April 05)

- Add narrow bandpass filters (~10MHz BW) to electronics to allow measurement of single modes at higher gain.
- Use 3 scopes to allow simultaneous measurement of both couplers in 4 cavities
- Narrowband (low noise !?) measurement on cavity 1 and 8 in a structure to provide high resolution beam position / angle measurement
- Narrow band measurement of selected cavity 2-7 with narrow band, high resolution..
- Broadband measurement using DESY 10Gs/s, 7GHz scope
 - Characterize full mode spectrum with better linearity and without aliasing problems.
- Integrate TTF BPM data (and models) to calibrate position and noise.

Current HOM measurements - problems

- Timing system still not able to provide trigger with stability $\ll 1/1.3\text{GHz}$
 - Need to use monopole HOMs for timing – offline only.
- Software buggy – crashes every few minutes – working to fix.
- Missing one narrowband filter, and 2 anti-alias filters. Expect in a few days.
- Mystery: HOM signals quite small < 1 Watt peak. Is this expected??
 - **DESY terminators designed for 50 Watts AVERAGE!**

Current HOM measurements

- Have measurements for ACC4, Cavities 1,2,3,4,8.
- Still processing data.
- Should be able to measure structure straightness
 - (expect answer in a few days).
- Expect to measure ACC4 and ACC5 all cavities

System for HOM based beam position measurement for all of the TTF Cavities

- Instrument all cavities, all couplers in TTF: 80 signals.
- Electronics down mix channels constructed as surface mount
 - Frequencies in telecom range – parts inexpensive
- Expect beam position relative to all cavities with few micron resolution.

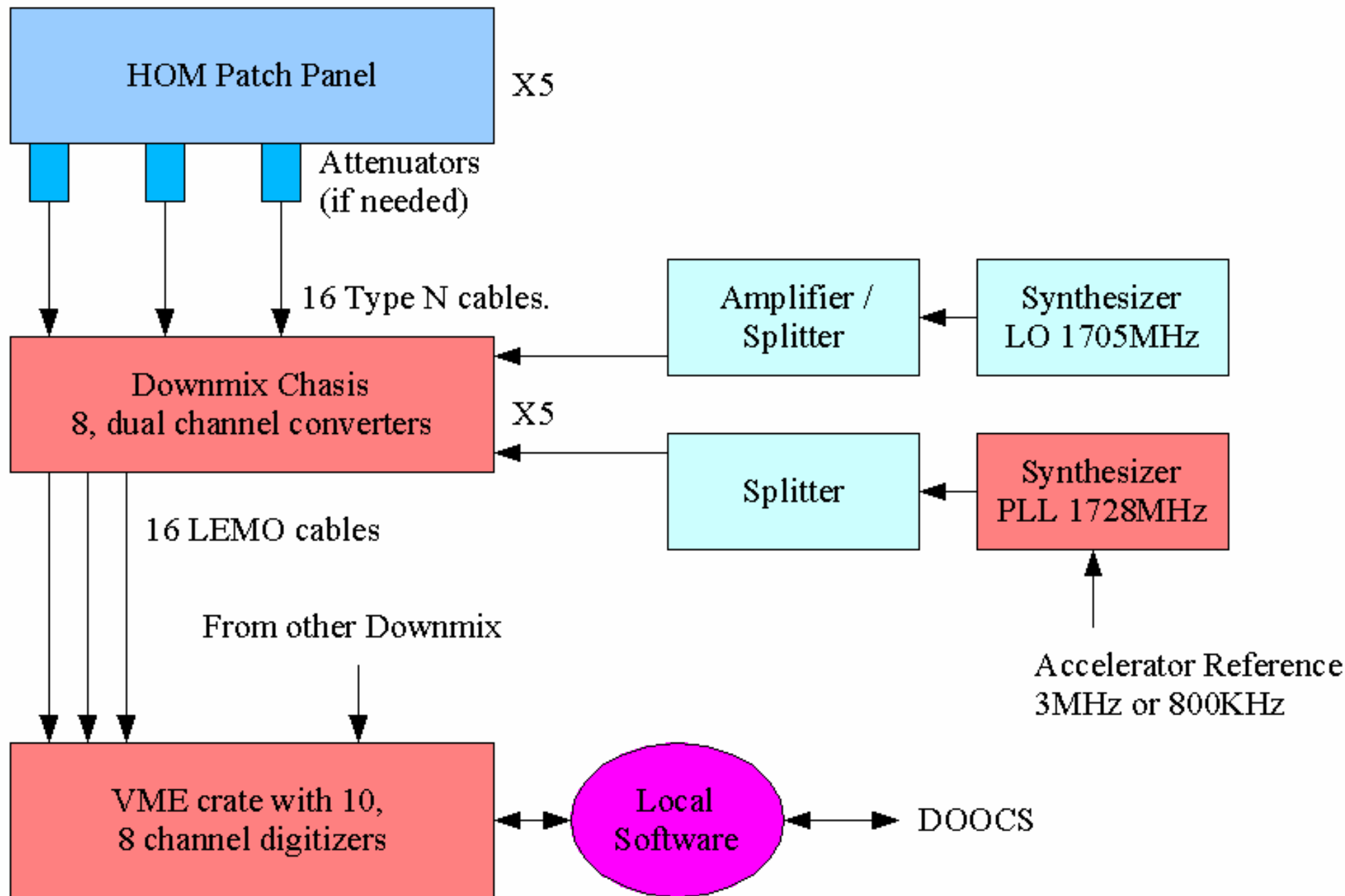

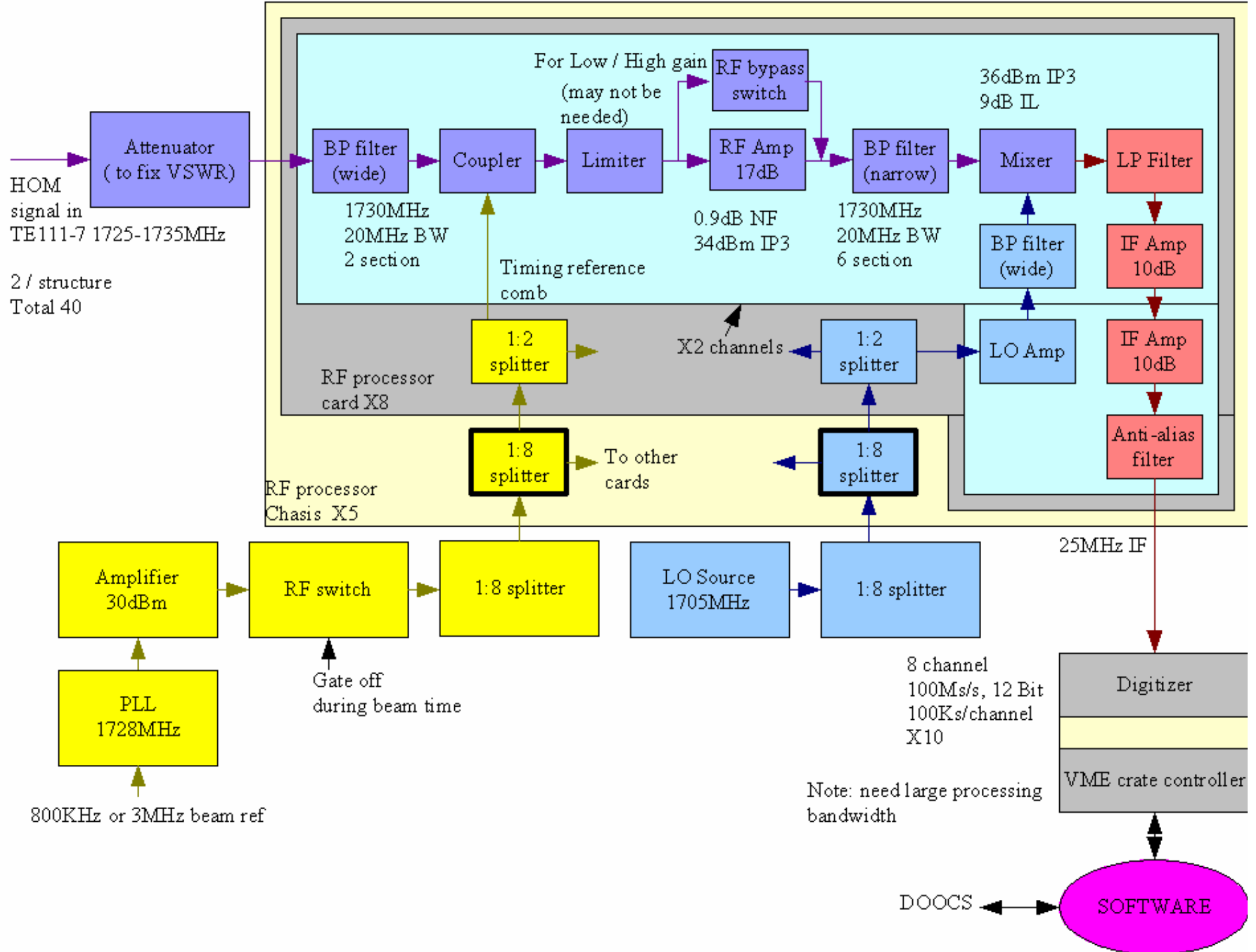

Multi-bunch Operation – Low Frequency

- For low bunch rate machines, for example the TTF (3MHz), use of HOMs is fairly straightforward
- HOM modes driven by each bunch
- In 300 nanoseconds can measure mode complex amplitude
- Calculate amplitude change after each bunch passes to find bunch position
- Reduced integration time (300ns vs. $\sim 10\mu\text{s}$) increases position noise by $\sim 5\text{X}$ per bunch (for the same single bunch charge)
 - ~ 10 micron resolution bunch by bunch still OK.
- If a HOM mode lies on a beam harmonic – will generate large amplitudes
 - This is bad for beam dynamics anyway.
 - Can choose a different mode in that cavity.

Summary

- Beam position measurements with 20 micron single bunch resolution have been demonstrated at the TTF2
- Expect straightforward improvement to 2 micron resolution by using narrow band filtering – Testing Now
- Possible to instrument entire TTF for HOM based beam position measurements.